

# Exploded parts list

3000/3600rpm Diesel Generator

**DHY8500SE-T**

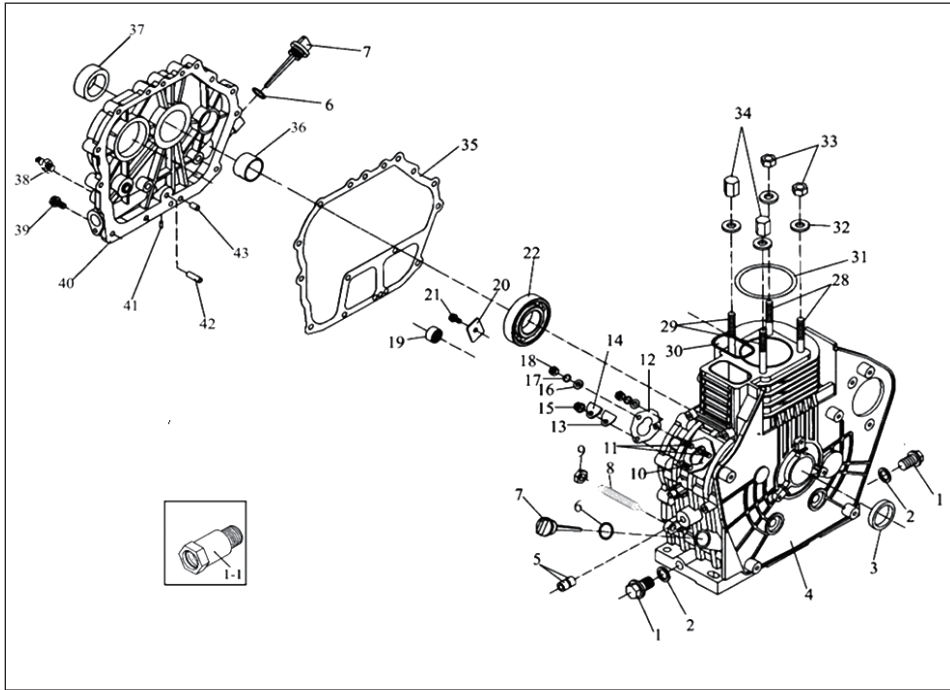



POS	REF	DESCRIPTION	配件	QTY
1-1	D500-A1-1	Drain plug screw M16×16×1.5	放油螺栓 M16 × 16 × 1.5	2
1-2	D500-A1-1	Connecting bolt of drain plug	放油螺栓接头	1
2	D500-A2	Washer unit of drain plug Φ16.5	放油螺栓垫片 Φ16.5	2
3	D500-A3	Real oil seal 35×50×8	后油封 35 × 50 × 8	1
4	D500-A4	Crank case	机体	1
5	D500-A5	Needle bearing HK081410	滚针轴承 HK081410	2
6	D500-A6	O-Ring Φ24×2.4	机油尺 O型圈 Φ24 × 2.4	2
7	D500-A7	Oil dipstick	机油尺	2
8	D500-A8	Fuel controller ASSY	油量控制器	1
9	D500-A9	Nut M10×1.25	螺母 M10 × 1.25	1
10	D500-A10	Bolt (short) AM6×30	喷油泵紧固螺栓 (短) AM6 × 30	1
11	D500-A11	Bolt (long) AM6×36	喷油泵紧固螺栓 (长) AM6 × 36	2
12	D500-A12	Fuel injection pump washer (0.1 ~ 0.5MM as optional)	喷油泵调整垫片 (0.1 ~ 0.5MM 可选)	1
13	D500-A13	Joint washer	喷油器密封板垫片	1
14	D500-A14	Seal plate	喷油器密封板	1
15	D500-A15	Nut M6	法兰螺母 M6	1
16	D500-A16	Flat washer Ø6	平垫 Ø6	2
17	D500-A17	Spring washer Ø6	弹垫 Ø6	2
18	D500-A18	Nut M6	普通螺母 M6	2
19	D500-A19	IKO Needle bearing TIA1512Z	IKO 滚针轴承 TIA1512Z	1
20	D500-A20	Thrust plate	止推片	1
21	D500-A21	Flange bolt M8×12	法兰螺栓 M8 × 12	1
22	D500-A22	Ball bearing 6308	轴承 6308	1
28	D500-A28	Cylinder head stud bolt(short) AM12×1.5×108	气缸盖双头螺栓(短) AM12 × 1.5 × 108	2
29	D500-A29	Cylinder head stud bolt(long) AM12×1.5×121	气缸盖双头螺栓(长) AM12 × 1.5 × 121	2
30	D500-A30	Rectangle ring 5.1×2.3	环形密封圈 5.1 × 2.3	1
31	D500-A31	Cylinder head shim 0.3MM	汽缸垫调整垫片 0.3MM	1
32-1	D500-A32	Cylinder head nut gasket Φ10.5	气缸盖螺母垫圈 Φ10.5	4
33	D500-A33	Cylinder head nut(short)	气缸盖螺母(短)	2
34	D500-A34	Cylinder head nut(long)	气缸盖螺母(长)	2
35	D500-A35	Crankcase cover washer	齿轮室盖垫片	1
36	D500-A36	Main bush	主轴瓦	1
37	D500-A37	Front oil seal 35×50×10	前油封 35 × 50 × 10	1
38	D500-A38	Low oil alarm	机油压报警器	1
39	D500-A39	Bolt M8×33.5	法兰螺栓 M8 × 33.5	16
40	D500-A40	Crankcase cover	齿轮室盖	1
41	D500-A41	Plunger 8×8	铝堵 8 × 8	3
42	D500-A42	Oil conduit	机油导管	1
43	D500-A43	Pin 8×12	定位销 8 × 12	2

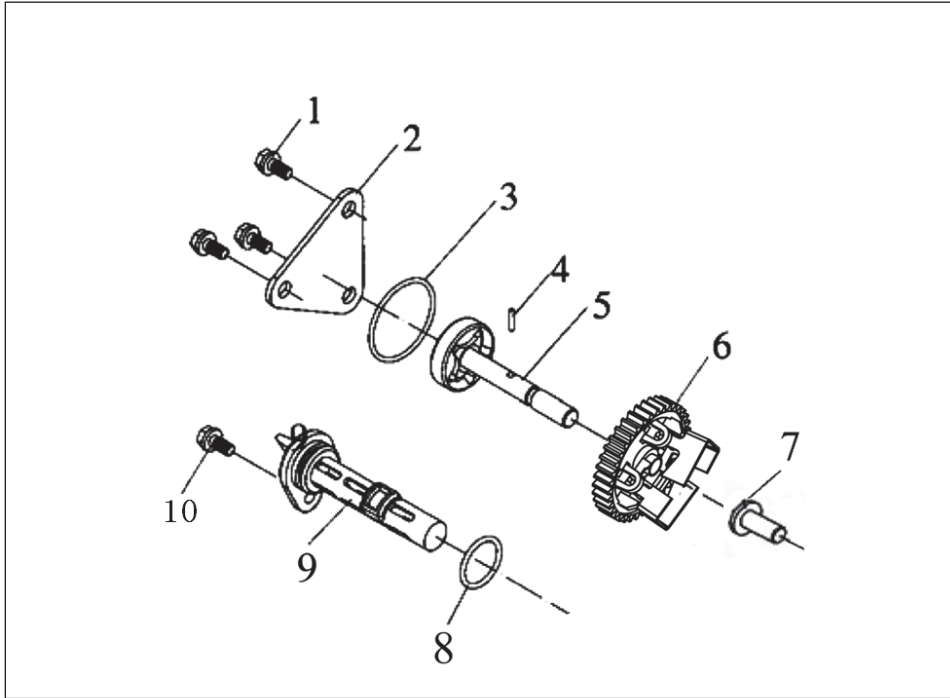

POS	REF	DESCRIPTION	配件	QTY
1	D500-B1	Bolt M6×12	法兰螺栓M6×12	3
2	D500-B2	Lube oil pump cover	机油泵盖板	1
3	D500-B3	O-Ring Φ34.5×1.8	O型圈 Φ34.5×1.8	1
4	D500-B4	Pin 3×16	销 3×16	1
5	D500-B5	Engine oil pump unit	机油泵	1
6	D500-B6	Drive gear of lube oil pump	机油泵传动齿轮	1
7	D500-B7	Governor push reel	调速器推盘24.5	1
8	D500-B8	O-Ring Φ20×2.52	O型圈 Φ20×2.52	1
9	D500-B9	Lube oil filter ASSY	机油滤总成	1
10	D500-B10	Bolt M6×14	法兰螺栓 M6×14	1

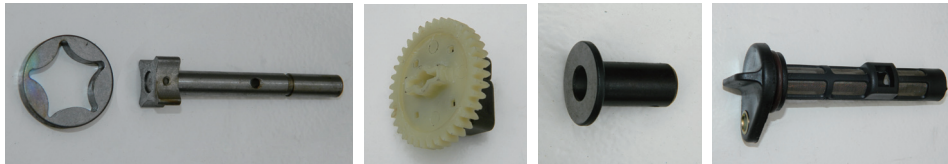

D500-B5

D500-B6

D500-B7

D500-B9

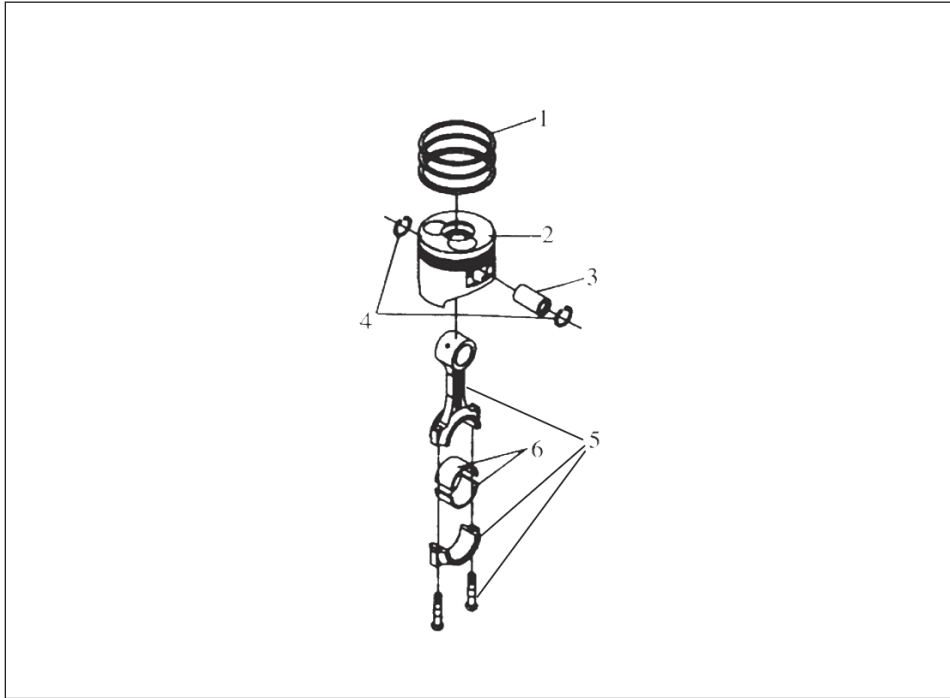

POS	REF	DESCRIPTION	配件	QTY
1	D500-C1	Piston ring set	活塞环(套)	1
2	D500-C2	Piston	活塞	1
3	D500-C3	Piston pin	活塞销	1
4	D500-C4	Piston pin clip	活塞销卡簧	1
5	D500-C5	Connecting rod ASSY	连杆总成	1
6	D500-C6	Connecting rod bush (Set)	连杆瓦(套)	1

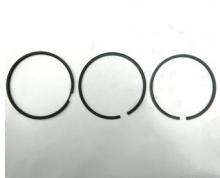

D500-C1



D500-C2



D500-C3



D500-C5

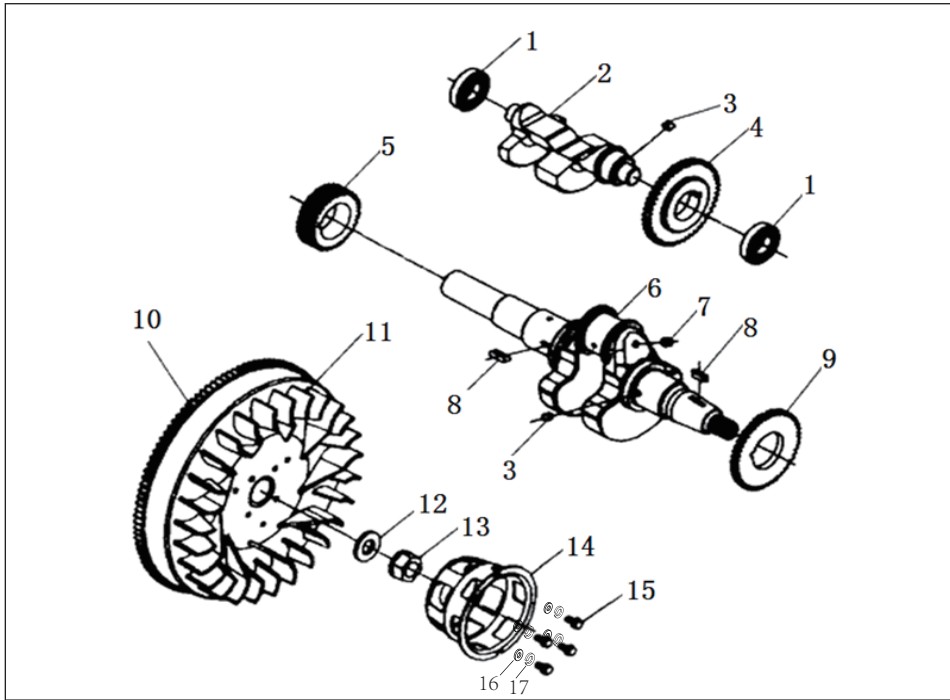

POS	REF	DESCRIPTION	配件	QTY
1	D500-D1	Ball bearing 6203	轴承 6203	2
2	D500-D2	Balance shaft	平衡轴	1
3	D500-D3	Key 5x7	键 5x7	2
4	D500-D4	Timing gear of balance shaft	平衡轴正时齿轮	1
5	D500-D5	Crankshaft timing gear	曲轴正时齿轮	1
6	D500-D6	Crankshaft	曲轴	1
7	D500-D7	Steel ball Ø6.35	钢珠 Ø6.35	1
8	D500-D8	Key 5x14	键 5x14	2
9	D500-D9	Drive gear of balance shaft	平衡轴传动齿轮	1
10	D500-D10	flywheel ring gear	飞轮齿圈	1
11	D500-D11	Flywheel	飞轮	1
12	D500-D12	Flywheel nut washer	飞轮螺母垫圈 Ø18.5	1
13	D500-D13	Flywheel Nut M18x1.5	飞轮螺母 M18x1.5	1
14	D500-D14	Starting claw	起动爪盘	1
15	D500-D15	Flang bolt M6x12	法兰螺栓 M6x12	4
16	D500-D16	Washer Ø8	平垫 Ø8	4
17	D500-D17	Spring washer Ø8	弹垫 Ø8	4



D500-D1



D500-D6



D500-D11

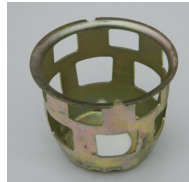

D500-D14-1

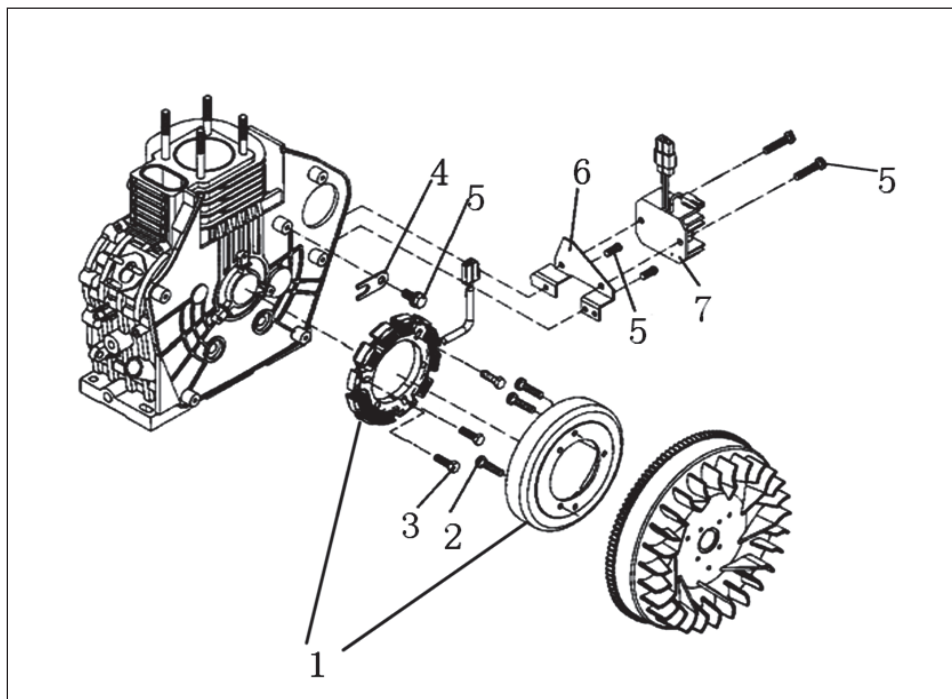

POS	REF	DESCRIPTION	配件	QTY
1	D500-E1	Flywheel alternator	飞轮发电机	1
2	D500-E2	Screw M6x12	十字槽沉头螺钉 M6 × 12	3
3	D500-E3	Screw M6x18	法兰螺栓 M6 × 18	3
4	D500-E4	Retainer plate	压线板	1
5	D500-E5	Screw M6x12	法兰螺栓 M6 × 12	5
6	D500-E6	Support of voltage regulator	稳压器支架	1
7	D500-E7	Voltage regulator ASSY	稳压器	1



D500-E1

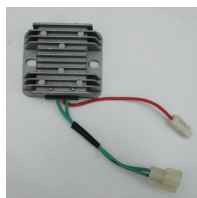

D500-E2

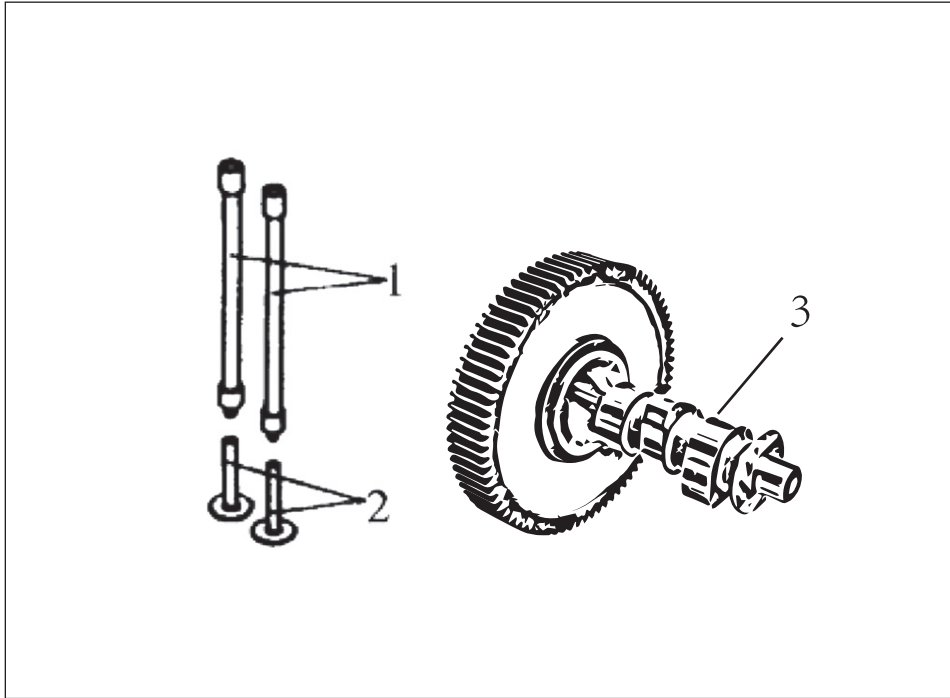

POS	REF	DESCRIPTION	配件	QTY
1	D500-F1	Valve push rod ASSY	气门推杆	2
2	D500-F2	Valve tappet	气门挺柱	2
3	D500-F3	Self-decompressing camshaft	自减压凸轮轴	1



D500-F1



D500-F2



D500-F3

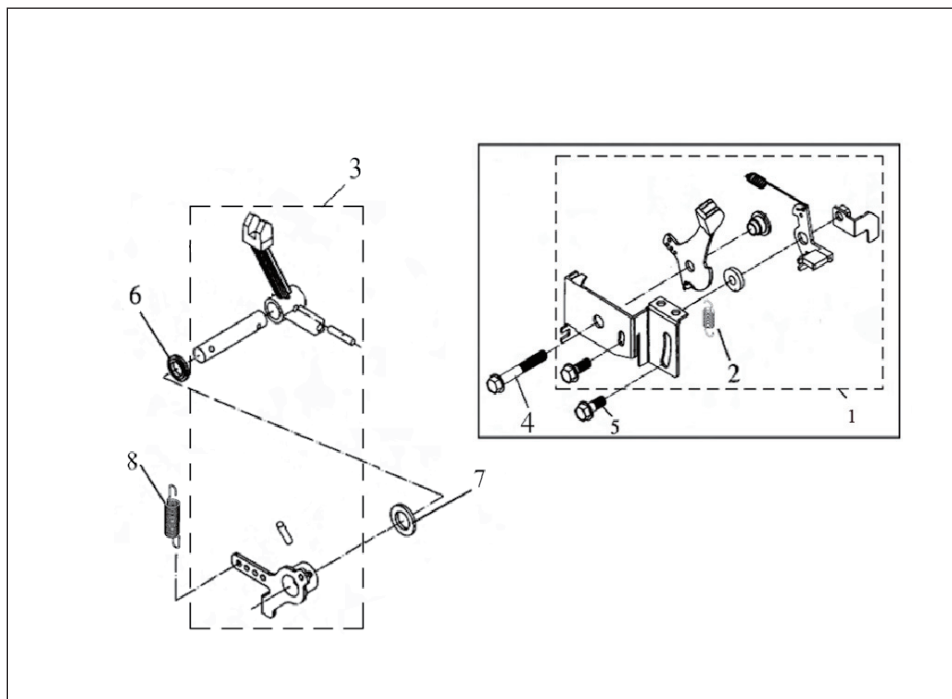

POS	REF	DESCRIPTION	配件	QTY
1	D500-G1	Stop-Start speed governor ASSY	二档手柄	1
2	D500-G2	Retrun spring II	回位弹簧 II	1
3	D500-G3	Governor level ASSY	拨插总成	1
4	D500-G4	Flange bolt M6x18	六角法兰螺栓M6x18	1
5	D500-G5	Flange bolt M6x14	六角法兰螺栓M6x14	1
6	D500-G6	Level shaft oil seal	杠杆轴油封	1
7	D500-G7	Level shaft gasket	杠杆轴垫片	1
8	D500-G8	Governor spring	调速弹簧	1
9	D500-G9	Retrun spring I	回位弹簧 I	1



D500-G1



D500-G3



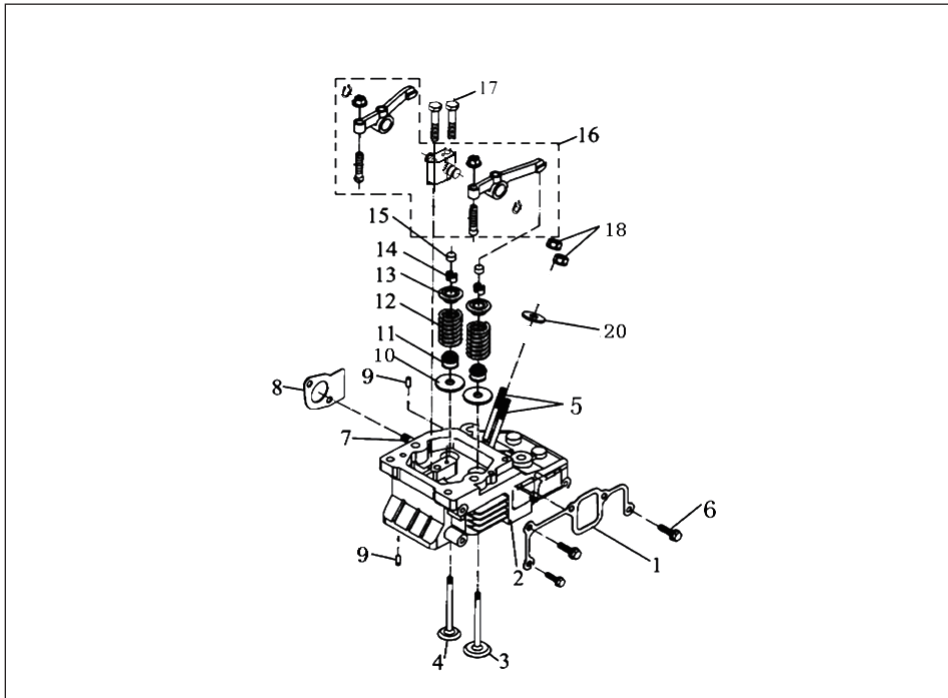

POS	REF	DESCRIPTION	配件	QTY
1	D500-H1	Intake pipe shim	进气管垫片	1
2	D500-H2	Cylinder head	气缸盖	1
3	D500-H3	Intake valve	进气门	1
4	D500-H4	Exhaust valve	排气门	1
5	D500-H5	Stud M6×45	双头螺栓 M6 × 45	2
6	D500-H6	Bolt M6×25	法兰螺栓 M6 × 25	3
7	D500-H7	Stud M10×25	双头螺栓 M10 × 25	2
8	D500-H8	Exhaust pipe washer	消声器垫片	1
9	D500-H9	Pin 4×8	销 4 × 8	3
10	D500-H10	Valve spring gasket	气门弹簧垫圈	2
11	D500-H11	Valve conduit oil seal	气门导管油封	2
12	D500-H12	Valve spring	气门弹簧	2
13	D500-H13	Valve spring seat	气门弹簧座	2
14	D500-H14	Valve retaining clip	气门锁夹	4
15	D500-H15	Valve Aadjusting cushion	气门调节垫块	2
16	D500-H16	Rock arm ASSY	摇臂总成	1
17	D500-H17	Set bolt of Rocker arm Sseat M8×1.25×50	摇臂紧固螺栓 M8 × 1.25 × 50	2
18	D500-H18	Flange nut M6	法兰螺母 M6	2
20	D500-H20	Injector adjustment washers(0.1~0.5MM as optional)	喷油器调整垫片 (0.1 ~ 0.5MM 可选)	1



D500-H2



D500-H3



D500-H4

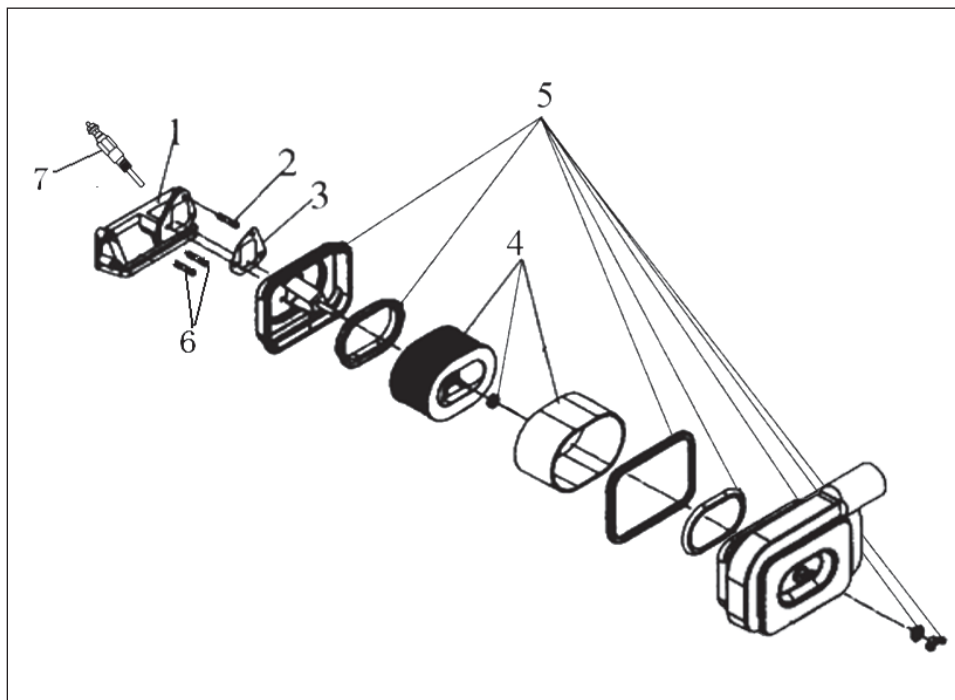

POS	REF	DESCRIPTION	配件	QTY
1	D500-I1	Inlet pipe	进气管 (带加热塞孔)	1
2	D500-I2	Flang bolt M6x12	法兰螺栓 M6x12	1
3	D500-I3	Air clearner gasket	空滤垫片	1
4	D500-I4	Air cleaner element ASSY	空滤芯(D500-450)	1
5	D500-I5	Air cleaner shell ASSY (soundproof type)	静音空滤壳	1
6	D500-I6	Flange bolt M6x75	法兰螺栓 M6x75	2
7	D500-I7	12V heating plug	12V加热塞	1

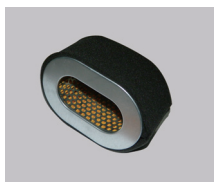

D500-I4



D500-I7

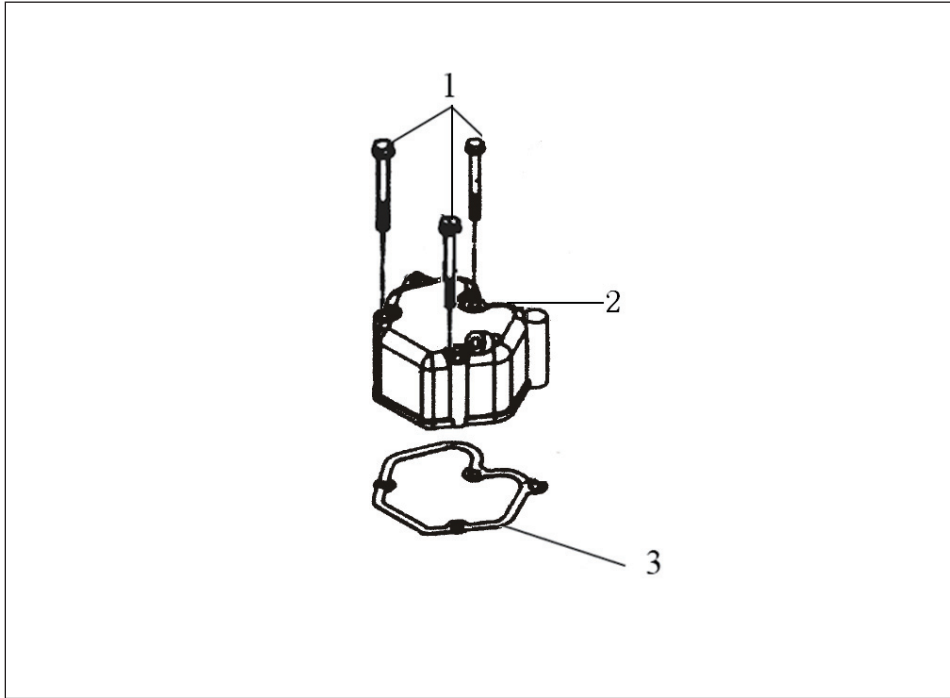

POS	REF	DESCRIPTION	配件	QTY
1	D500-J1	Bolt M6×70	法兰螺栓 M6 × 70	3
2	D500-J2	Cylinder head cover ASSY (Engine, Generator)	气缸盖罩总成 (单机, 机组专用)	1
3	D500-J3	Cylinder head cover gasket	气缸盖罩垫片	1



D500-J2

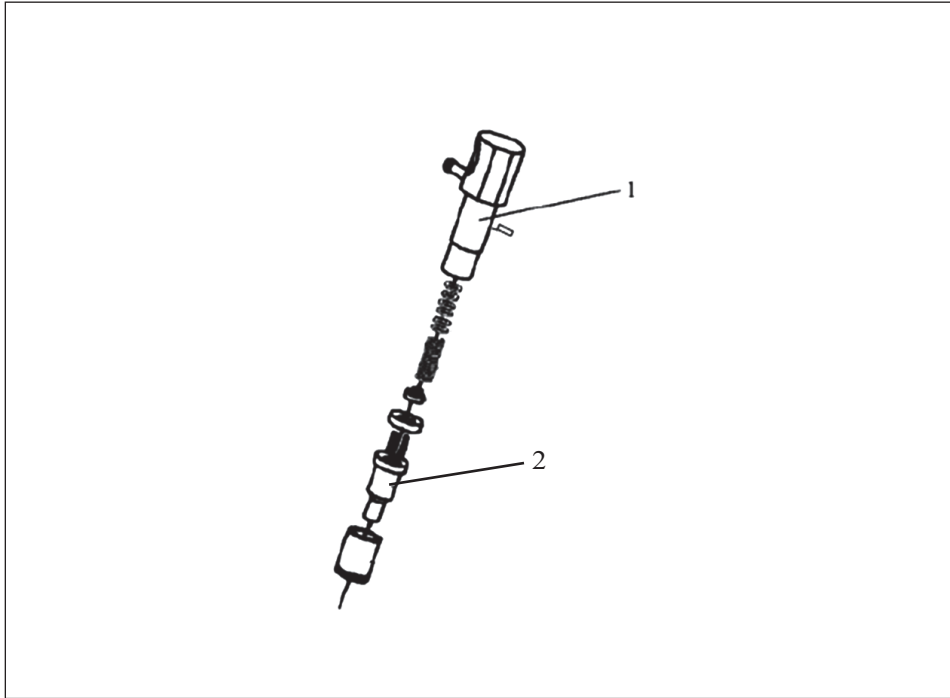

POS	REF	DESCRIPTION	配件	QTY
1	D500-K1	Injector ASSY	喷油器总成	1
2	D500-K2	Injection nozzle	喷油器偶件	1



D500-K1



D500-K2

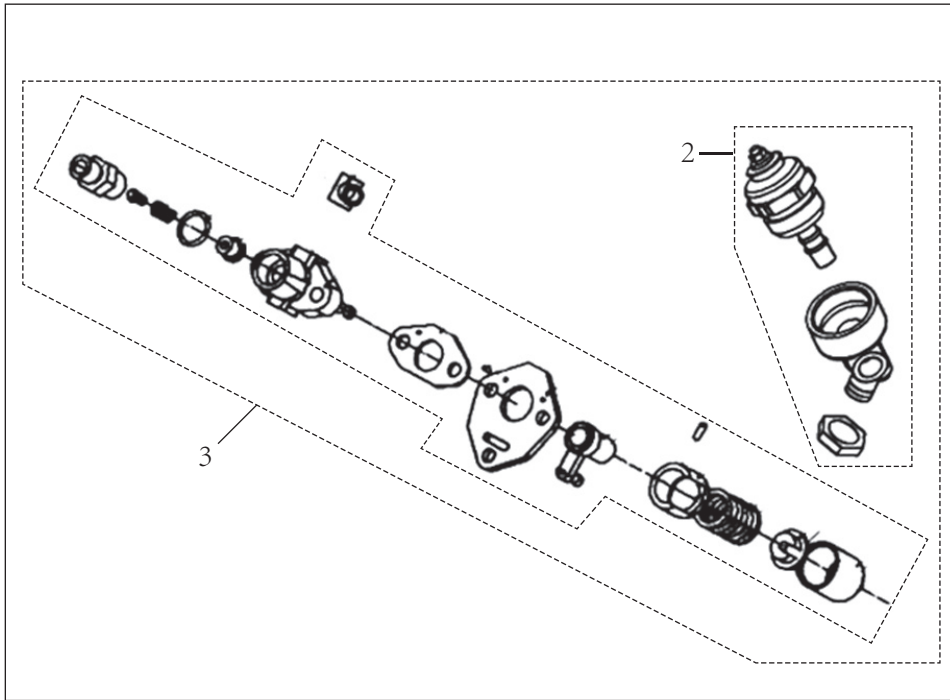

POS	REF	DESCRIPTION	配件	QTY
2	D500-L2	Electromagnetic valve	电磁阀	1
3	D500-L3	Injection pump ASSY (electromagnetic valve included)	机组喷油泵总成 (带电磁阀)	1



D500-L2



D500-L3

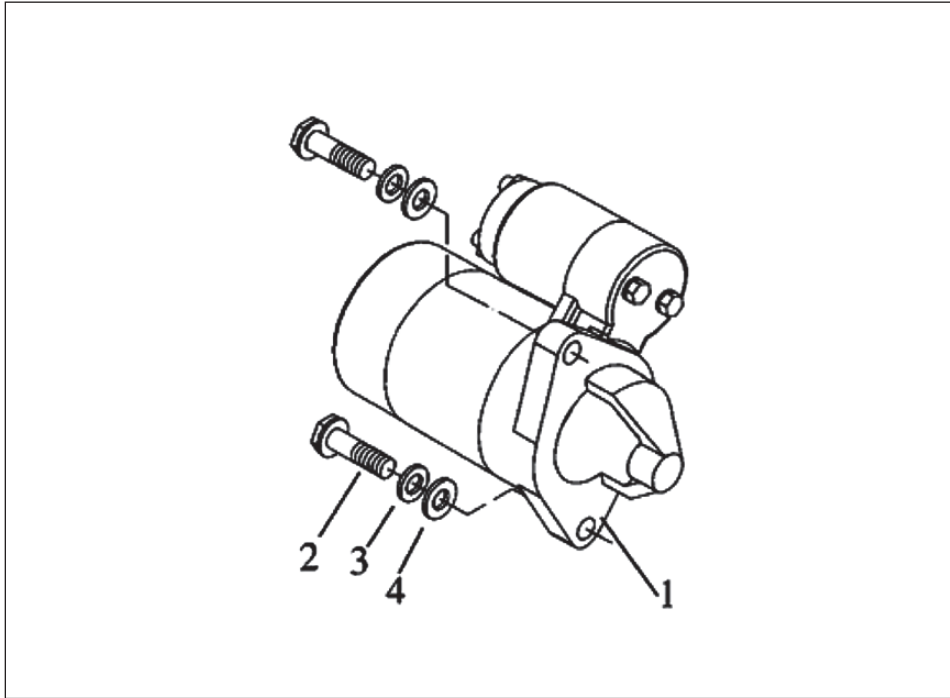

POS	REF	DESCRIPTION	配件	QTY
1	D500-M1	Starting motor ASSY	起动电机	1
2	D500-M2	Bolt M10×35	六角螺栓 M10×35	2
3	D500-M3	Spring gasket Φ10	弹垫 Φ10	2
4	D500-M4	Flat washer Φ10	平垫 Φ10	2



D500-M1

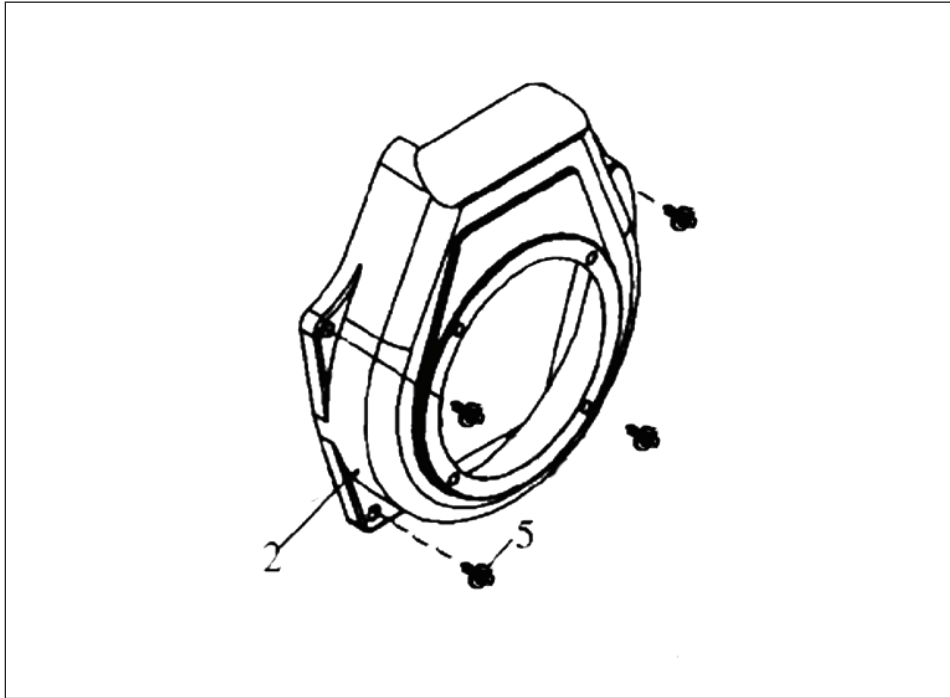

POS	REF	DESCRIPTION	配件	QTY
2	D500-N2	Fan cover weldment ASSY (soundproof type)	静音导风罩	1
5	D500-N5	Combination bolts M6×22	组合螺栓 M6×22	4



D500-N2

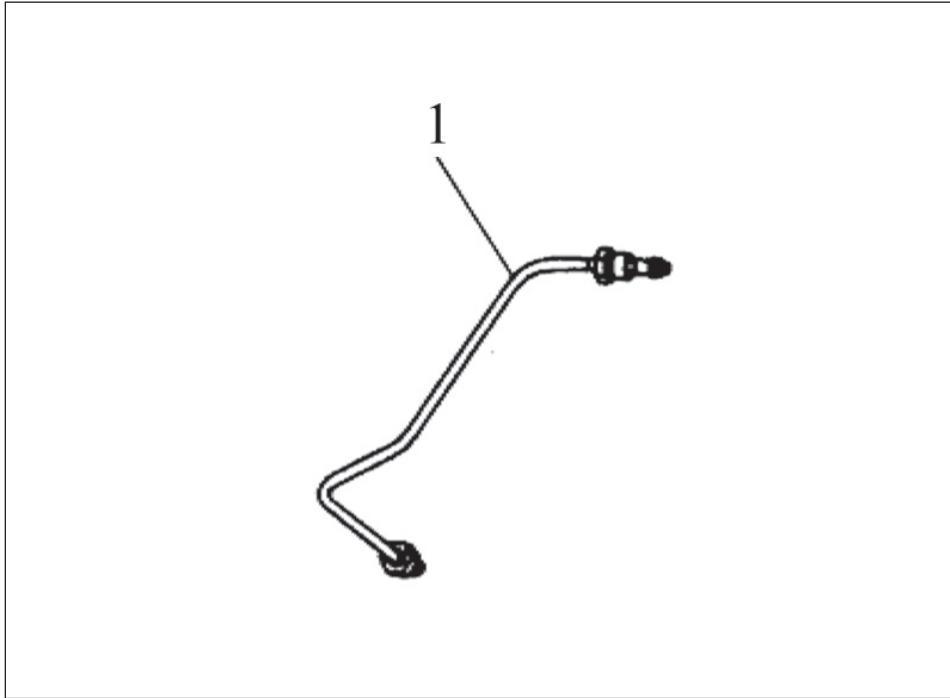

D500-01

POS	REF	DESCRIPTION	配件	QTY
1	D500-01	High-pressure tube(soundproof type)	静音高压油管	1



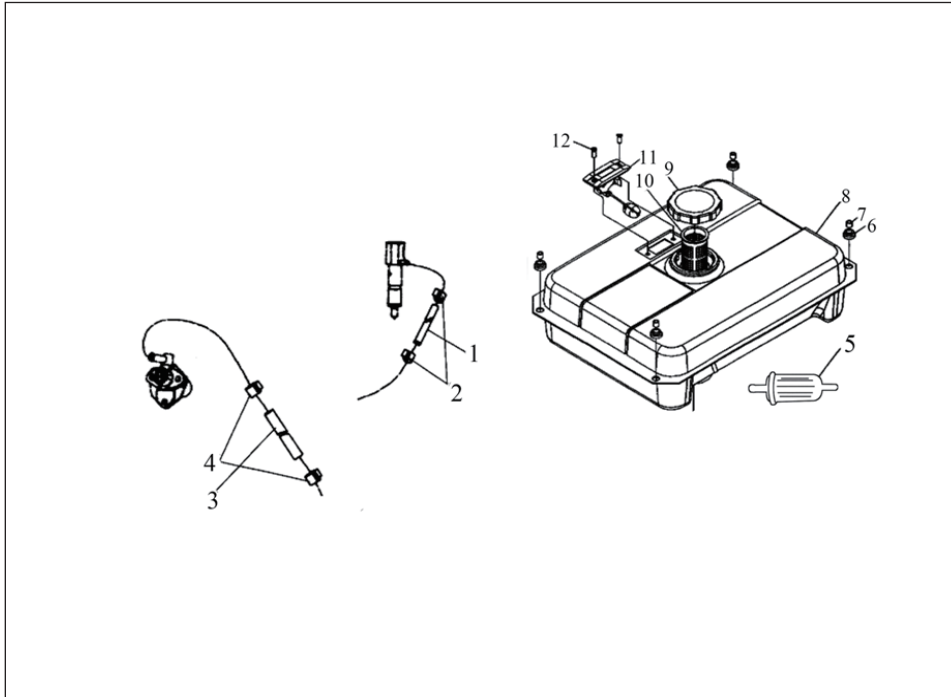

POS	REF	DESCRIPTION	配件	QTY
1	D500-R01	Fuel return pipe $\phi 5 \times 9.5$	回油管 $\phi 5 \times 9.5$	1
2	D500-R02	Fuel return pipe clip $\varnothing 8$ , $\varnothing 8.5$ as optional	回油管卡箍 $\varnothing 8$ 或者 $\varnothing 8.5$	2
3	D500-R03	Fuel pipe $\phi 7.5 \times 13$	输油管 $\phi 7.5 \times 13$	1
4	D500-R04	Fuel pipe clip $\varnothing 13$	输油管卡箍 $\varnothing 13$	2
5	D500-R05	External fuel filter	外置柴油滤芯	1
6	D500-R06	Vibration isolation cushion block	引风板减震垫	4
7	D500-R07	Sheath	引风板减震衬套	4
8	D500-R08	Fuel tank (soundproof type)	静音油箱	1
9	D500-R09	Fuel tank cap	油箱盖总成	1
10	D500-R10	Fuel filler screen	柴油滤网	1
11	D500-R11	Fuel level indicator ASSY (soundproof type)	静音油位指示器	1
12	D500-R12	Screw M5 $\times$ 8	十字盘头螺钉M5 $\times$ 8	2



D500-R05

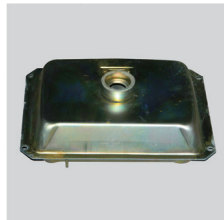

D500-R08-1

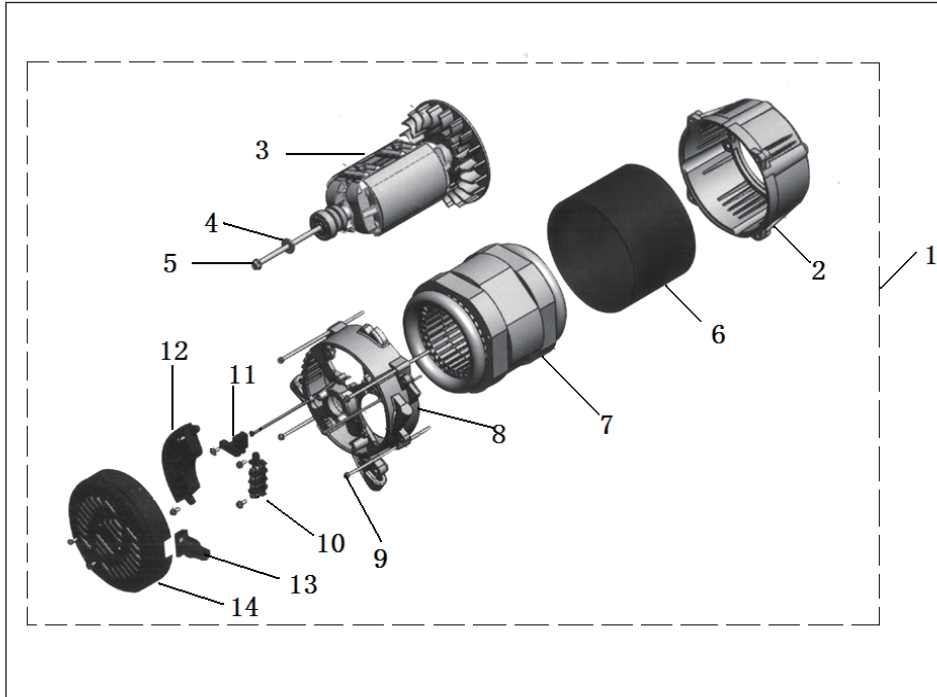

POS	REF	DESCRIPTION	配件	QTY
1-2	D500-S01-2	6KVA Alternator ASSY(SE) (full power)	6KVA等额定音电机总成	1
2	D500-S02	Front round cover(SE/SE-3) (soundproof type)	静音电机前端盖	1
3-2	D500-S03-2	6KVA Rotor(LE/SE) (full power)	6KVA等额定电机转子	1
4	D500-S04	Flat washer $\Phi$ 10	$\Phi$ 10平垫	1
5	D500-S05	6KVA Axis bolt	6KVA中心轴螺栓	1
6	D500-S06	6KVA Stator cover	6KVA定子护圈	1
7-2	D500-S07-2	6KVA Stator(LE/SE) (full power)	6KVA等额定电机定子	1
8	D500-S08	Real round cover	电机后端盖	1
9	D500-S09	6KVA Frange bolt M6 $\times$ 170	6KVA法兰螺栓 M6 $\times$ 170	1
10-2	D500-S10-2	Terminal plate(LE/SE) (full power)	等额接线排	1
11	D500-S11	Brush kit	碳刷	1
12-2	D500-S12-2	AVR(LE/SE) (full power)	等额AVR	1
13	D500-S13	Rubber cable cover	电机出线护套	1
14	D500-S14	Real end cover	电机进风罩	1



D500-S02-1

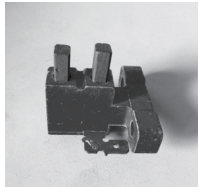

D500-S11



D500-S12

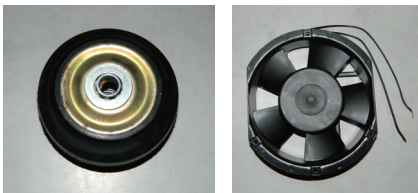
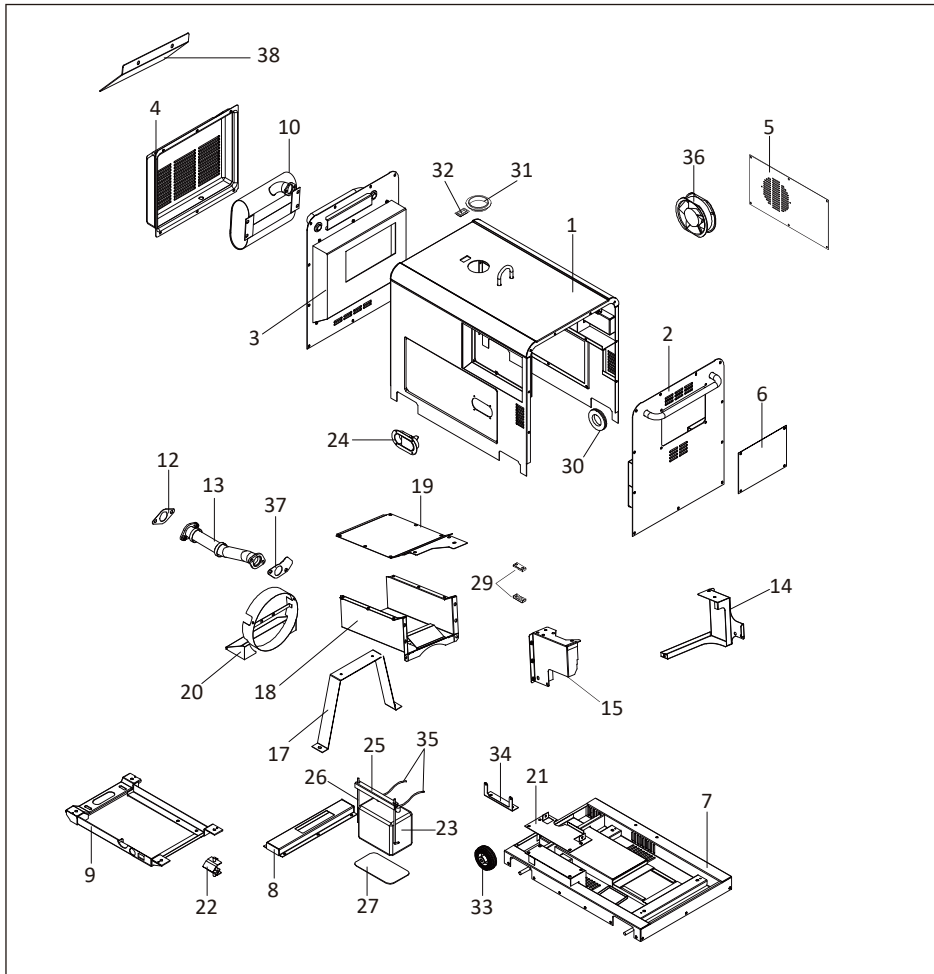

D500-U33

D500-U36

POS	REF	DESCRIPTION	配件	QTY
1	D500-U01	Canopy upper cover	静音外罩	1
2	D500-U02	Right cover	空滤侧板	1
3	D500-U03	Left cover	消声器侧板	1
4	D500-U04	Muffler cover	消声器护罩	1
5	D500-U05	Real door	外罩后门板	1
6	D500-U06	Air filter door	空滤盖板	1
7	D500-U07	Base chassis	底盘	1
8	D500-U08	Base chassis real cover	底盘电机进气盖板	1
9	D500-U09	Engine support	托架	1
10	D500-U10	Muffler ASSY	消声器总成	1
12	D500-U12	Muffler gasket	消声器垫片	1
13	D500-U13	Bellows	波纹管	1
14	D500-U14	Inside part 1	发动机引风板1	1
15	D500-U15	Inside part 2	发动机引风板2	1
17	D500-U17	Inside part 4	U型槽支架	1
18	D500-U18	Inside part 5	U型槽	1
19	D500-U19	Inside part 6	U型槽盖板	1
20	D500-U20	Inside part 7	Φ204电机后罩	1
21	D500-U21	Inside part 8	电瓶托架	1
22	D500-U22	Rubber absorber	减震垫	4
23	D500-U23	Battery	电瓶	1
24	D500-U24	Front door handle	外罩门锁	1
25	D500-U25	Battery fastening plate	电瓶压板	1
26	D500-U26	Battery fastening rod	电瓶拉杆	2
27	D500-U27	Battery rubber base plater	电瓶皮垫	1
29	D500-U29	High pressure pipe clip	高压油管固定夹	2
30	D500-U30	Rubber round cover for air inlet pipe	空滤进气口密封圈	1
31	D500-U31	Rubber round cover for fuel tank	油箱口密封圈	1
32	D500-U32	Fuel tank indicator door	油位显示窗	1
33	D500-U33	4 inch wheel	4寸单轮	4
34	D500-U34	AVR support	AVR支架	1
35	D500-U35	Battery cable (both of red and black)	电瓶线总成	1
36	D500-U36	35W Electric fan	35W 风扇	1
37	D500-U37	Muffler gasket	消声器垫片	1
38	D500-U38	Baffle	挡板	1

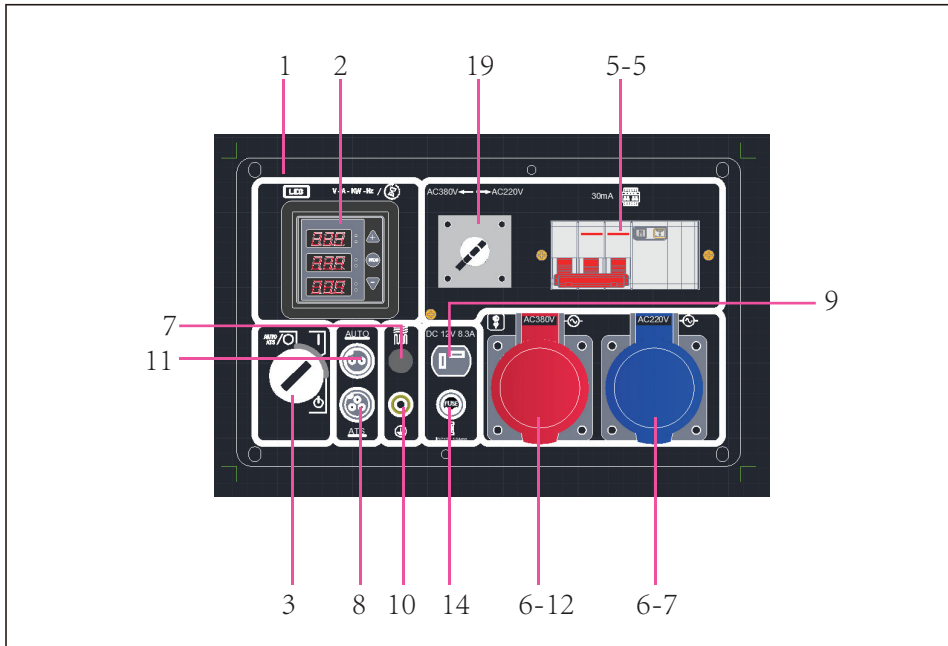

POS	REF	DESCRIPTION	配件	QTY
1	D500-V01	Panel plate	面板	1
2	D500-V02-1	LED6	LED6	1
3	D500-V03	Key starter	电门锁	1
5-5	D500-V05-5	Breaker 3P+N	断路器3P+N	1
6-7	D500-V06-7	220-250V Europe blue socket 32A	220-250V蓝色欧插32A	1
6-12	D500-V06-12	Industrial five holes socket 3-phase 32A	三相五孔工业插32A	1
7	D500-V07	Air pre-heater button	加热塞按钮	1
8	D500-V08	ATS socket	ATS插座(母头)	1
9	D500-V09	T-type 12V/DC connector	12V T型插座	1
10	D500-V10	Grounding nut	接地螺母	1
12	D500-V12	ATS module	ATS模块	1
13	D500-V13	Rectifier 12V	整流桥12V	1
11	D500-V11	Two core socket	两芯插座	1
14	D500-V14	Fuse kit	保险丝座	1
15	D500-V15	Relay	启动继电器	1
19	D500-19	Universal switch LW39B-16A D404.4	万能转换开关LW39B-16A D404.4	1

